

Fabrication

#9 Painting

This brief gives advice for:

- Equipment
- Procedures
- Trouble Shooting
- Equipment and Materials Suppliers
- Additional Technical Information and Assistance

Equipment and Materials

The crystal clarity and long-term weatherability of ACRYLITE FF acrylic sheet allow for painting and printing on fabricated signs, displays, and other decorative items. Using the correct materials will help you produce a quality product.

Paints

The increased use of ACRYLITE FF sheet in signs and other decorative applications has led to a variety of paints designed especially for acrylics. Most are supplied as concentrates and require thinner to obtain the correct viscosity. As a rule, use a mild thinner consisting of an alcohol blend, rather than one containing aromatic hydrocarbons. Benzene and toluene are two examples of aromatics. Follow paint suppliers' recommendations on the amount and type of thinner.

ACRYLITE FF sheet's extraordinary transparency allows backpainting—applying paint to the side of the material that will not be exposed to the weather. Thus, the unpainted outer surface of the acrylic provides weather protection for the paint. However, if you must paint the outer surface, apply a protective coating over the paint. Paint suppliers can recommend a suitable coating.

Spraying Systems

Any efficient atomizing spray gun system which will uniformly distribute paint may be used. Consult equipment suppliers regarding the equipment needed for a particular application. See the listing of suppliers at the end of this brief. Many paint suppliers also publish excellent manuals which provide up-to-date equipment suggestions.

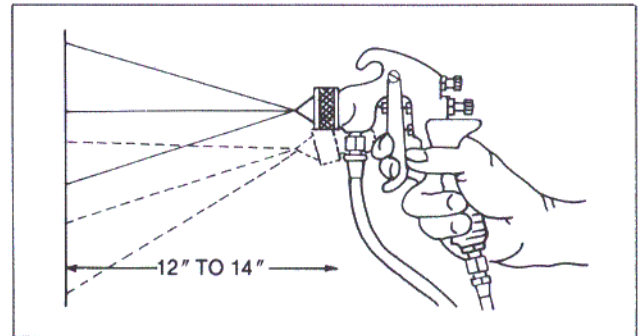

To obtain enough atomizing air, the available line pressure should be in the range of 60-90 psig. Use a 25-ft., 5/16"-minimum-diameter hose to avoid pressure drops in the line. The air compressor should be large enough to provide the volume and pressure required for all guns. It's important to control water and oil in the atomizing air since this will spot the paint and cause non-uniform distribution. Water and oil traps in the line will alleviate the problem.

Equipment cleanliness is crucial to uniform paint dispersion. Place metal screen strainers at the pressure tank and spray gun. Clean these items and the spray gun daily.

Install a spray booth large enough to fit your largest work piece. Make sure it's adequately vented according to building code regulations: It's important to use a light box to judge paint uniformity on transparent plastics. Be sure the light box conforms with building code regulations for a spray painting area.

Procedures

Be sure to follow the manufacturers' safety recommendations for equipment and materials used with ACRYLITE FF acrylic sheet.

Fabrication Techniques

If you fabricate ACRYLITE FF sheet prior to painting, incorrect techniques may cause heat build-up, resulting in crazing (numerous tiny cracks in the material) after painting. Foregoing Tech Briefs #2 through #8 discuss many aspects of fabrication. To ensure that crazing will not occur, review these briefs to assure your fabrication techniques are correct.

Cleaning

Clean ACRYLITE FF acrylic sheet before painting to remove dust and assure paint adherence. Since acrylic sheet is sensitive to solvents such as aromatic hydrocarbons, concentrated alcohols, and ketones, use care in cleaning. Clean parts with a 25% solution of denatured alcohol and distilled water. However, for stains such as oil or grease, use a stronger cleaning agent such as hexane, aliphatic naphtha, or kerosene. Be sure the sheet is fully dry and clean before painting.

Static Neutralization

Before painting, it's important to neutralize electric or static charges which accumulate on the sheet's surface. Dust on the sheet causes paint agglomeration and uneven layers. Since tearing the masking off the sheet will create a static charge, all acrylic pieces should be treated.

One common way to do this is with an ionizing air gun. These guns safely and effectively neutralize electric charges. Alternate techniques, such as wiping the sheet with a damp, lint-free cloth or cleaning with a dilute alcohol-water solution, are also effective.

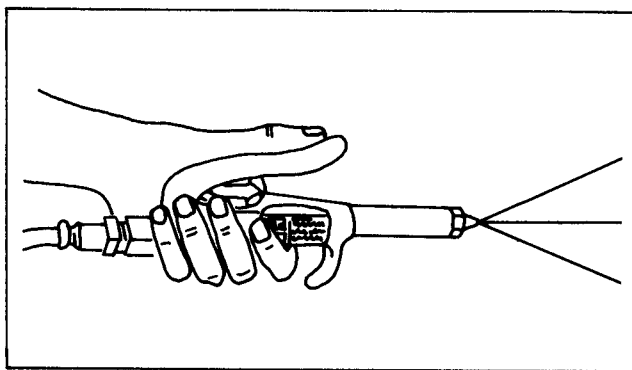

Avoid anti-static cleaners since they may leave a residue and cause paint adhesion problems.

Maskants

The protective paper masking is usually used as a protective layer for spray painting flat signs. However, many paint manufacturers also distribute liquid maskants, which are commonly used to spray paint designs onto ACRYLITE FF sheet. Maskant is supplied as a thick liquid consisting of water-soluble latex resins in solution. Because they are water solutions, maskants must be stored above 32°F to prevent freezing. Application is through the use of air or airless atomizing spray equipment—see the drawing on the first page of this brief.

Clogging may occur due to dried film mixed with the solution. To prevent this, obtain a special nozzle which reverses the flow of product and cleans out the build-up. These nozzles are available from the suppliers of painting equipment listed at the end of this brief. Spray the film on evenly to a wet film thickness of 10-12 mils, which will dry to above 4-5 mils.

Maskant Drying

Drying time is usually about 2 hours, although it's better to plan overnight drying to assure complete evaporation. Drying can be accelerated by using forced-air heating at 110°F—don't go above this temperature as doing so might dry the surface and prevent evaporation of the water in the layers beneath.

Leave the dried film in place until you're ready to paint to prevent dust accumulation on the plastic surface. Just before painting, score the design on the film using an X-Acto knife (available in art supply stores), giving it just enough pressure to cut the film without scratching the plastic. After painting, leave the film in place until the paint is thoroughly dry. Otherwise, you'll get smeared paint and uneven edges.

Painting

Before painting, practice on a few test pieces to be sure that paint viscosity and air pressure are correct. Too high a delivery rate will result in too much paint and cause paint sag. It may also cause crazing due to too much solvent. Too low a delivery rate will result in "dry spray," a matte surface caused by too much dusting.

As a rule, use the lowest pressure at which you obtain correct results. Hold the gun 12-14 inches from the workpiece—too close or too far will cause the above-listed defects. Move the gun at an even pace and in a straight line. Its movement should never start or stop directly on the sheet surface.

Vary the direction of the spray, horizontally and vertically, to assure uniform coverage. Usually, four or five passes with several seconds between coats will provide sufficient paint. As mentioned, a light box behind the ACRYLITE FF sheet will help in judging the uniformity and intensity of color.

Screen Printing

Screen printing is used for volume production. It is fast and economical. For beginners, it is best to purchase a screen from a local screen supply house. After setup, apply paint with the squeegee in a uniform, even motion in one direction. It will pass through the open mesh on the screen, transferring the pattern onto the acrylic. The most important factors in the screening process are the paint's viscosity and the size of the mesh openings. These will determine paint flow through the screen and the paint's appearance on the acrylic.

Since many different fabrics are used for screening and paint viscosity depends on the application and temperature conditions, it's difficult to generalize on what these conditions should be. Paint manufacturers give advice on thinning paint. Consult these companies should you need information.

Paint Removal

If you need to remove paint from the surface of ACRYLITE FF sheet, take it off immediately with the paint manufacturer's recommended cleaner. Apply the remover using a rag; wipe off paint using a clean rag. Because paint removers contain organic solvents, minimize the time the remover is in contact with acrylic to reduce the chance of crazing.

Trouble Shooting

<u>Problem</u>	<u>Cause</u>	<u>Solution</u>
<u>M A S K A N T S</u>		
Weak and brittle maskant	Air bubbles in film	Dilute slightly
	Film not thoroughly dry	Wait recommended drying time
Too much adhesion	Maskant film too thin	Increase film thickness to 3-5 mils (10-12 mils wet)
	Maskant film too thin	Increase film thickness to 3-5 mils (10-12 mils wet)
	Coating exposed to UV	Do not store faces outside
<u>S P R A Y P A I N T S</u>		
Poor adhesion	Incorrect paint	Use paints recommended for use with acrylic
	Dirt or residue on sheet	Clean sheet thoroughly before painting
Blotches of paint	Static electricity	Neutralize charges with ionizing gun, or: Wipe with damp cloth
	Uneven paint application	Apply paint in more passes using less paint per pass
	Paint not applied uniformly	Use backlighting to check paint as it is being applied
<u>S C R E E N P A I N T S</u>		
Poor detail	Screen mesh too coarse	Use a finer mesh screen
	Paint too thin	Use less thinner
	Worn screen	Replace screen
Paint drying on screen	Hot, dry weather	Add retarder to slow paint drying
	Too much time between screening	Flood screen between passes
Crazing	Stress from fabrication	Review fabrication techniques—briefs 2 through 8
	Flame polishing	Flame polish as last step

The problems listed represent the most common concerns when painting ACRYLITE FF sheet. Most paint manufacturers publish excellent paint manuals which contain much more detailed information on troubleshooting paint problems. Consult these manuals or the paint manufacturer regarding problems not covered here.

Equipment and Materials Suppliers

Paints

Lacryl 800 Series (Screen)
Lacryl 400 Series (Spray)
Spraylat Corporation
716 South Columbus Avenue
Mount Vernon, NY 10550
(914) 699-3030

Grip-Flex FR-1 (Screen)
Grip-Flex FR-2 (Spray)
AKZO-Nobel Co.
Wyandotte Paint Products
6369 Peachtree Street
Norcross, GA 30071
1-800-233-3301

70-000 Series Ink
59-000 Gloss Enamels
Naz-Dar Paint Products
1087 N. North Branch Street
Chicago, IL 60622
(312) 943-8338

Paint Removers

Consult paint manufacturers for recommended remover(s).

Liquid Latex Maskants

Sign Strip
Spraylat Corporation
716 South Columbus Avenue
Mount Vernon, NY 10550
(914) 699-3030

Grip Mask
AKZO-Nobel Co.
Wyandotte Paint Products
3669 Peachtree Street
Norcross, GA 30071
1-800-233-3301

Anti-Static Air Guns

The Simco Company
920 Walnut Street
Lansdale, PA 19446
(215) 248-2171

Painting Equipment

Binks Manufacturing Company

9201 West Belmont Avenue
Franklin Park, IL 60131
(213) 671-3000

The DeVilbiss Company

P.O. Box 913-T
Toledo, OH 43692
(419) 470-2169

Knives to Cut Masking Film

X-Acto

45-35 Van Dam Street
Long Island City, NY 11101
(Knives available in art supply stores)

Additional Technical Information and Assistance

Technical Literature Available

For more detailed information, see your local Authorized ACRYLITE Sheet Distributor or contact CYRO Industries. Literature is available for these and other topics:

Physical Properties—

#1121—"Physical Properties of ACRYLITE FF Acrylic Sheet"

Fabrication Tech Briefs—

These cover individual operations of fabrication such as cutting, drilling, thermoforming, etc. Be sure to ask for the latest listing of available Tech Briefs from your ACRYLITE sheet distributor or CYRO Industries.

Application Tech Briefs—

These cover required fabrication operations for specific applications like glazing, signs, etc.

Technical Service

For complete technical assistance contact CYRO Industries, Technical Service:

CYRO Industries
25 Executive Blvd.
Orange, CT 06477
(203) 795-6081

In Canada:
CYRO Canada Inc.
6285 Northam Drive
Suite 100
Mississauga,
Ontario L4V 1X5
(905) 677-1388
(800) 268-4743

Offices

For the name of your local Authorized Distributor call toll-free 1-800-223-2976 or contact the nearest CYRO office:

Rockaway, NJ 07866
100 Enterprise Drive
P.O. Box 5055
(201) 442-6130

San Ramon, CA 94583
3180 Crow Canyon Place
Suite 240
(510) 866-9300

Plano, TX 75074
101 East Park Blvd.
Suite 1039
(214) 424-6830

Naperville, IL 60563
280 Shuman Blvd.
(630) 357-0822

In Canada:

CYRO Canada Inc.
6285 Northam Drive
Suite 100
Mississauga,
Ontario L4V 1X5
(905) 677-1388
(800) 268-4743

Fire Precautions

ACRYLITE FF acrylic sheet is a combustible thermoplastic. Precautions should be taken to protect this material from flames and high heat sources. ACRYLITE FF acrylic sheet usually burns rapidly to completion if not extinguished. The products of combustion, if sufficient air is present, are carbon dioxide and water. However, in many fires sufficient air will not be available and toxic carbon monoxide will be formed, as it will when other common combustible materials are burned. We urge good judgement in the use of this versatile material and recommend that building codes be followed carefully to assure it is used properly.

Important Notice: The information and statements herein are believed to be reliable but are not to be construed as a warranty or representation for which we assume legal responsibility. Users should undertake sufficient verification and testing to determine the suitability for their own particular purpose of any information or products referred to herein. **NO WARRANTY OF FITNESS FOR A PARTICULAR PURPOSE IS MADE.** Nothing herein is to be taken as permission, inducement or recommendation to practice any patented invention without a license.



CYRO Industries, Rockaway, NJ 07866